

Woodworking Machines

Woodworking Machines - Shapers

On this page

[What should you do before using shapers?](#)

[What should you avoid when using shapers?](#)

[What safety procedures should you follow when using shapers?](#)

What should you do before using shapers?

Shapers can be dangerous if not used properly.

- Read the owner's manual carefully.
- Make sure you understand instructions before attempting to use any tool or machine. Only trained, experienced personnel should be allowed to operate wood shapers.
- Learn the applications and limitations before use.
- Refer to [Woodworking Machines - General Safety Tips](#) for general safeguards.

What safety procedures should you follow when using shapers?

- Wear safety glasses with side shields or safety goggles, or a face shield (with safety glasses or goggles).
- Wear hearing protection that is suitable for the level and frequency of the noise you are exposed to in the woodworking area.
- Wear protective footwear when required.
- Wear respiratory protection when required.
- Use the cutter (and spindle speed / RPM) suited for the job.
- Use sharp cutters only and keep them clean.
- Remove all wrenches and tools used in the set up from the table.

- Check moving parts of the shaper periodically such as belts and pulleys for signs of wear; also check the spindle for burrs or for excessive runout.
- Make sure all guards are in proper position.
- Before operating, check that the spindle is square with the shaper table; that the spindle top and knives are correctly adjusted and securely fastened; and that the spindle is free before turning on the power. If in the wrong position, cutters may make a "chattering:" noise or appear loose. Turn off the power, unplug the machine, and correct any issues before continuing.
- Operate at speeds recommended by the manufacturer.
- Use jig fixtures, holders, and hold-down push blocks. Fasten the work securely in a jig. When a table guide pin is used, make sure it is adjusted and will not slip.
- Cut with the grain rather than against it.
- Remove all other blades when one blade is removed from the shaper spindle. This will prevent the other blades from being hurled from the spindle if the machine is started.

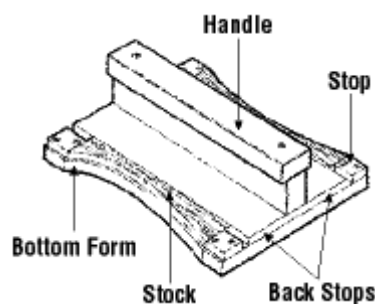

- Turn off power, and lock out a machine when making any adjustments or changes in the set up..
- Shape only one piece of stock at a time.
- Use extra care in machining stock that contains cross grains or knots. These may pull the operator's hands into the knives or may cause kickbacks.
- Shape stock only if longer than 25 cm (10 in).
- Support long pieces of wood with extension tables or roller supports.

What should you avoid when using shapers?

- Do not leave a shaper machine running. Make sure that the power is shut off and that the cutter head has stopped revolving before leaving the area.
- Do not rest your hands near the edge of the stock being cut.

- Do not tamper with the guards or make them inoperative in any way.
 - Do not back up the stock (check to see that the direction of rotation is as expected). Always feed against rotation of the cutter.
 - Do not make deep cuts or feed the stock too rapidly.
 - Do not cut stock that has loose knots, splits, defects or foreign objects (e.g., metal, stone) in it.
 - Do not distract or startle an operator during a shaping operation.
 - Do not remove saw dust or cuttings around knives by hand or with compressed air. Use a stick or brush.
 - Do not clear the table while the cutter is rotating.
 - Do not accumulate stock or finished work on the table.
 - Do not stand in line with the stock being fed.
 - Do not wear loose clothing, work gloves, neckties, rings, bracelets or other jewellery that can become entangled with moving parts.
-

Fact sheet last revised: 2019-08-09

Disclaimer

Although every effort is made to ensure the accuracy, currency and completeness of the information, CCOHS does not guarantee, warrant, represent or undertake that the information provided is correct, accurate or current. CCOHS is not liable for any loss, claim, or demand arising directly or indirectly from any use or reliance upon the information.